

2022 State Softball Event Handbook



Special thanks to the
2022 Softball Tournament Sponsors

Gold Medal Sponsors
Illinois Knights of Columbus
Law Enforcement Torch Run
Casey's General Stores
United Airlines
Dunkin'
Jewel Osco
Jersey Mike's
Gallagher
Sloane Valve Company
PACIRA Biosciences, Inc.

Hello,

Congratulations and welcome to the 2022 Special Olympics Illinois State Softball Tournament! The staff of Special Olympics Illinois extend their best wishes for your athletes' success at this year's tournament. **State Softball is a one-day competition in 2022 due to lower participation numbers.**

This handbook is designed to answer as many of your questions as possible and make your trip to the tournament an enjoyable experience. Instructions for registration, meals, the Opening Ceremony, medical assistance, a tentative schedule of events and other general information are contained in this handbook. Please make sure to read the handbook carefully since there have been changes made from last year.

During the tournament, please take time to thank the many volunteers who make this competition the success that it is. Also, take a moment to thank the staff at Evergreen Racquet Club for being a part of the Special Olympics Illinois Tennis Tournament.

Good luck,

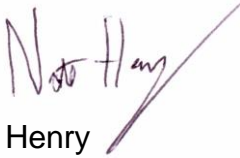

Nate Henry
Director of State Championships



**Special
Olympics**
Illinois

2022 Softball Tournament Event Handbook

Table of Contents

Competition Information

2022 Tentative Schedule of Events	1
Coach's Responsibilities	2
Code of Conduct.....	3
Registration.....	4
Facilities.....	4
Competition Brackets.....	5-6
Team Play.....	6
Individuals Skills Competition	6
Disqualification.....	6
Filing Protests/Awards/Results	7

Meals	8
--------------------	----------

Medical Information, COVID Guidelines & PPE	8
--	----------

Activities/Entertainment

Opening Ceremony.....	9
Souvenirs.....	9

Families/Guests

Guest/Family Meals	9
Family Program	9

Safety

Water Safety Policy	10
---------------------------	----

Emergency Phone Numbers.....	10
-------------------------------------	-----------

Tentative Schedule of Events 2022 Special Olympics Illinois State Softball Tournament

Saturday, September 10th, 2022

8:30am - 10:00am	Agency Registration
8:30am – 9:00am	Warm Up for Competition
9:00am – 9:30am	Opening Ceremony
9:00am - 12:00pm	Family Information and Registration Area Open
9:00am – 2:00pm	Souvenir Sales & Pre-Order Pick Up
10:00am – 4:00pm	Team Play
10:00 am – 12:00 p.m.	Softball Individual Skills Competition
11:00 am - 1:30pm	Lunch

Coach's Responsibilities

It is important that coaches are adequately prepared to supervise their athletes for an extended period of time.

1. The coach is responsible for the athletes 24 hours a day. It is up to the coach to ensure the athletes' physical and emotional needs are met during the tournament.
 - a. Be sure athletes are properly warmed up prior to competition.
 - b. Make sure needed first aid is administered promptly. Bring a first aid kit if possible to deal with minor problems not needing professional attention.
 - c. Be sure athletes get adequate rest.
 - d. Make sure athletes eat properly and avoid overeating or missing meals.
NOTE: If an athlete requires a special diet, it is the responsibility of the coach to provide for the athlete's needs. For special diets, bring a cooler with all the proper foods and snacks for athletes who need to eat at a specific time.
2. Each coach should be aware of the athlete's possessions. Check for lost items at Tournament Central.
3. The coach is expected to be totally familiar with the medical conditions, precautions and medication requirements of the athletes. It is the coach's responsibility to administer medication. Knowledge of the medication regimen (what, how much and when) is essential.
4. The coach is required to carry a copy of the valid Application for Participation for each athlete at all times.
5. The coach must be totally familiar with all schedules. Make sure that the athletes are on time for their games or events so they do not miss the opportunity to compete.
6. The coach is expected to be familiar with sports rules.
7. NO ALCOHOLIC BEVERAGES ARE ALLOWED. Agencies breaking alcohol use rules will be disciplined by Special Olympics Illinois.
8. SMOKING IS NOT PERMITTED AT THE VENUE SITES. Smoking is not permitted on Evergreen Racquet Club property.
9. Communicate with families of the athletes. Inform them of the upcoming tournament and encourage them to attend the Special Olympics Illinois Tennis Tournament.

Spectator Attendance & Code of Conduct

Spectator Code of Conduct: As fans (family, friends and supporters) of Special Olympics athletes, it is expected that everyone will play a positive role at Special Olympics Illinois events by following these codes for conduct:

1. Refrain from using abusive or offensive language towards anyone: officials, coaches, opponents and fellow spectators.
2. Remember that athletes are amateur athletes and the coaches and officials are volunteers.
3. An understanding of the rules may lead to a more positive experience at the event. All Special Olympics Illinois sports follow the designated National Governing Body (NGB) rules and any exceptions or modifications to those rules are included in the Special Olympics Illinois Rules Interpretations for the sport. A list of the designated NGB rules and the Rules Interpretations can be found at www.soill.org in the coach section.
4. Keep in mind the Special Olympics oath and remember that winning is not the emphasis of Special Olympics competition.
5. Coaches should be the ones to do the coaching. Please refrain from shouting instructions to athletes.
6. Spectators and fans are prohibited in the competition areas. Only registered coaches, athletes and officials should be in the playing area.
7. ALL CHEERS should be positive and display good sportsmanship. Derogatory comments directed to players, coaches and officials will not be tolerated.
8. Follow instructions or directives given by officials, volunteers or Special Olympics Illinois staff.
9. Special Olympics Illinois has a no tolerance policy to physical altercations involving coaches, athletes, unified partners, volunteers, spectators, family members, etc.

Any spectator who fails to follow directives given by volunteers, officials or Special Olympics Illinois staff or does not adhere to the code of conduct items above will be reprimanded. A reprimand could include one of the following:

Will be escorted from the venue;

Will be banned from attending future events for a given period of time;

Will be permanently banned from attending any Special Olympics Illinois event.

Registration for Agencies

Land of Lincoln Sports Complex
8:30am – 10:00am

1. Only the Head Coach should report to the registration area and bring a state or federal issued photo ID.
 2. Verify numbers of coaches and athletes who are actually attending the tournament. The Head Coach will either agree to verify the identity of all of his/her agency coaches/chaperones or these individuals will be required to present their photo ID for verification.
 3. Report the names of those registered as of Scratch Deadline but are unable to attend (no shows). No mementos or meal tickets will be issued in the name of “no show” athletes, coaches or unified partners.
 4. The Head Coach must verify wristbands and count mementos at the registration table to be certain adequate numbers have been included in the packet.
 5. Receive the tournament Coach’s Packet containing:
 - a. Computer printout listing your agency’s athletes/partners and their divisions.
 - b. Tournament mementos for athletes, coaches and unified partners.
 - c. Tournament Information.
- * If your agency is scheduled for a later competition time, you can register closer to your scheduled game time. Please allow at least a half-hour to register and be ready for competition.

State Softball Facilities

The competition is held at the Land of Lincoln Sports Complex. All events including individual skills and team play competition are conducted at LOJOS. If change is needed, coaches will be sent information regarding the schedule changes.

For text alerts during the event please text “Softball” to 844-393-0980.

Competition Brackets

Competition brackets indicating divisions and game times will be available to agency coaches prior to the tournament. The goal of Special Olympics Illinois is to create four person divisions whenever possible for state tournament play. In some cases, divisions of two or three athletes must be designed in order to provide appropriate competition at the state tournament. In such cases, special rules apply so that each athlete is given a fair and equal opportunity to achieve success. The following explanation covers all bracketing procedures to be employed by Special Olympics Illinois for tournament play.

Four Team Divisions: In a four-person bracket, each athlete plays twice. Athletes that win first round games move to the right side of the bracket, and athletes that lose first round games move to the left side of the bracket. The two winning athletes then play for 1st and 2nd place; the losing athletes play for 3rd and 4th place.

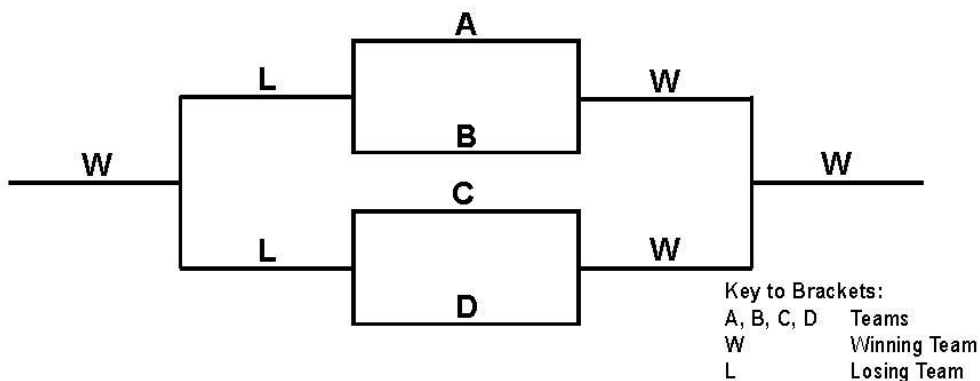

Three Team Divisions: All play is round robin style. In these divisions, three games will be played with athletes competing twice. The athlete with the best record at the end of the three games will receive first place. If all three athletes win one game and lose one game, places of finish will be determined:

1. By the point differential in the games played during the tournament.
2. If the point differential is the same, by the total points scored by each athlete during the tournament (highest scoring team receives first place).
3. If point differential and point totals are the same, places of finish will be determined by the highest number of service aces.

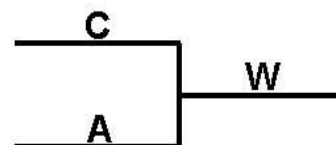
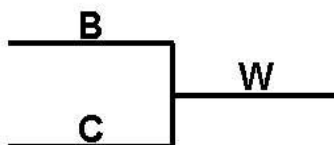
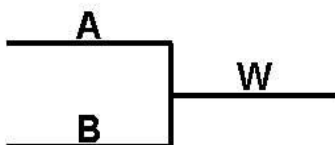

Two Team Divisions: All play is best two of three games. Athletes will be given adequate time to rest between games and should a division go to a third game, the final game will be highlighted for its championship status. In two person divisions, first round games will be played on one day with second round games played the following morning and third round games, if necessary, played late in the afternoon.



Team Play Competition

Athletes competing in team play competition are required to wear appropriate attire. Athletes will not be allowed to compete in jeans or jean shorts.

Individual Skills Competition

Softball Individual Skills will take place on Saturday, beginning at 10:00am. Athletes are divisioned based on their Region qualifying score. The place of finish is determined by the athlete's final score at the state tournament. Athletes competing in Skills are required to wear appropriate athletic attire. Athletes will not be allowed to compete in jeans or jean shorts.

Disqualification of Athletes

Disqualifications will be handled in accordance with Special Olympics Illinois' Disqualification Process:

1. It is the coach's responsibility to be aware of disqualifications at all times. Event officials will be signaled of infractions by course judges. Event officials will not announce disqualifications to the general audience.
2. Disqualified athletes will be given notice of the rule infraction upon completion of the event.
3. A Competition Rules Committee will be available to hear questions concerning disqualified athletes.
4. Awards will be presented upon completion of the event which includes: running of the event; notice of disqualification if necessary; appeal of disqualification if brought forth; and final decision of Competition Rules Committee.
5. Decisions of the Competition Rules Committee will be final and binding.
6. Disqualified athletes will receive a participation ribbon. An athlete who is disqualified for unsportsmanlike conduct will not receive a participation ribbon.
A team found using an ineligible or illegal player will forfeit all awards.
7. No disqualification protest will be heard once awards have been completed.

Sport Coaches Filing Protests

1. Protests to the Games Rules Committee may be made concerning only Games presentation, structure and conduct.
2. Protests to the Competition Rules Committee may be made concerning only competition of athletes within a venue, where within that competition; rulings are either made or not made in regard to fairness and equity of competition. Procedural or technical issues may be protested. Judgment calls made by the official may not.
3. Protests must be presented by the Sport Head Coach to the Head Official of the event immediately in an oral fashion so that other event officials may be made aware of the appeal. Any verbal protests must be made prior to the presentation of awards. (All awards for the division in question will be held until a resolution of the protest.)
4. If the awards presentation has taken place the sport coach has 30 minutes after the awards presentation to file a protest. A corrected awards presentation will be made to that athlete if needed.
5. The Head Official may rule immediately on appeals. If the response of the Head Official does not resolve the protest, a formal protest may follow.
6. All formal protests must be made by the Sport Head Coach within 30 minutes of the event being protested.
7. All formal protests must be made on the specified form obtained from the Head Official.
8. All protests will be brought to the Competition Rules Committee for a final resolution. The decision of this committee shall be final and binding unless this committee concludes that the protest concerns Games presentation, structure or conduct, and refers the protest to the Games Rules Committee.

Athlete Awards

Awards will take place immediately following completion of competition in each division. In case of protests, awards for the division in question will be presented once the protest is adjudicated by the Rules Committee. Medals are awarded to all athletes who finish first, second or third and ribbons are awarded to 4-8 place finishers. In cases of disqualification, athletes will receive a participation ribbon. In cases of ties, awards will be presented using the Olympic format, i.e., 1st, 2nd, 2nd, 3rd, 4th, 5th, 6th, 7th.

Results from Competition

Special Olympics Illinois will post the results to the website at www.soill.org after the Tournament. Go to the Results Table to secure an athlete's score or place of finish; do not ask event officials or awards presenters; this will delay the process of presenting awards to Special Olympics athletes.

Meals for Athletes and Coaches

SOILL will provide lunch at Land of Lincoln Sports Complex and a stipend for dinner. Stipend info will be shared with agencies after the tournament entry deadline. If an athlete requires a special diet, it is the responsibility of the coach to provide for the athlete's needs. Provisions for special dietary needs of athletes/partners or coaches cannot be made by Special Olympics Illinois. For special diets, bring a cooler with all the proper foods and snacks for athletes who need to eat a specific meal.

Medical Information for Athletes and Coaches

Trained medical personnel will be at the competition site during the weekend.

Special Olympics Illinois has an accident insurance policy which provides secondary coverage for all athletes, coaches and volunteers. This is provided as backup coverage to your personal insurance. Accident claim forms will be available at Medical Stations or Tournament Central.

Coaches **MUST** carry a copy of each athlete's current Special Olympics Illinois Medical Form or the equivalent of information provide on the form with them at all times.

COVID, PPE & ATTENDANCE BY HIGH RISK INDIVIDUALS

Even with the vaccine, there is no way of completely eliminating the risk of infection. Please review the High Risk Fact Sheet in the Resource Section of the State Softball Website Page to assist in determining risks you may face by attending in-person activities.

Special Olympics Illinois is following current State of Illinois COVID requirements. Masks are recommended for indoor venues.

Participants or agencies must provide masks and other needed PPE. Special Olympics Illinois will not provide masks. Hand sanitizer, disinfectant wipes/spray and other cleaning/sanitizing products will be provided on-site.

Opening Ceremony

The Opening Ceremony will begin at 9:00 am at the Land of Lincoln Sports Complex on Saturday. There will be a torch run and all other components of a typical Opening Ceremony.

Souvenirs

State Softball Tournament specific items and items you want customized are available by pre-order only. A limited supply of general Special Olympics Illinois merchandise will be sold on-site, Saturday 9am – 2pm. Pre-order deadline is September 5. Use this link to connect to State Softball Tournament merchandise options:

https://orders.minervapromotions.com/soill_state_softball_tournament/shop/home

Souvenir items are offered by Minerva Promotions and a percentage of sales are given to Special Olympics Illinois.

Families

The family registration and information area will be open on Saturday from 9:00am until noon. All families are encouraged to stop by for a free raffle ticket for some cool SOILL swag and to let us know you're here.

Guest/Family Meals

LOJOS will have concessions to purchase food & drink. There are a variety of restaurants in the Springfield area. Information about area restaurants will be available at the Family Center (see above). Meals will be provided only to registered athletes and coaches.

Water Safety Policy

All Special Olympics Illinois swimming training, competition and recreational sessions shall be conducted in accordance with basic safety practices as specified in the Sports Rules Book, Section C of the swimming section. Briefly, this policy specifies that in all swimming activities, there must be a certified lifeguard on duty while Special Olympics Illinois athletes are in the water. This policy is in place for training and competition as well as recreational aquatic activities off-site, such as use of a hotel pool.

Emergency Telephone Numbers

Tournament Central	309-242-7602
Fire Department - Non-emergency	(217) 788-8474 (or 911)
Police Department - Non-emergency	(217) 788-8311 (or 911)

Let me win. But if I cannot win. Let me be brave in the attempt.

Special Olympics Illinois
State Headquarters
605 East Willow Street
Normal, IL 61761-2682
309-888-2551

www.soill.org



***Special
Olympics***
Illinois

Special Olympics Created by the Joseph P. Kennedy, Jr. Foundation.
Special Olympics Illinois, Inc. Authorized and Accredited by Special Olympics, Inc.
for the Benefit of Persons with Intellectual Disabilities.